



---

## PALM BEACH METROPOLITAN PLANNING ORGANIZATION

---

2300 N. Jog Rd., 4<sup>th</sup>.Floor, West Palm Beach, Florida 33411-2749

Phone 561.684.4170 Fax 561.242-7165 www.PalmBeachMPO.org

### **BICYCLE, GREENWAYS, AND PEDESTRIAN ADVISORY COMMITTEE (BGPAC) – AGENDA**

DATE: THURSDAY, May 1, 2014  
TIME: 8:30 A.M. – 4:00 P.M.  
PLACE: Vista Center 4<sup>th</sup> Floor Conference Room 4E-12  
2300 North Jog Road  
West Palm Beach, Florida

***\*\*\*Meeting will Focus Primarily on the Evaluation of Year 2014  
Transportation Alternative Program (TAP) Grant Application  
Submissions\*\*\****

---

#### **1. REGULAR ITEMS**

- A. Roll Call
- B. Comments from the Chair
- C. MOTION TO ADOPT Agenda for May 1, 2014
- D. MOTION TO APPROVE Minutes for April 10, 2014
- E. Coordinator's Report

Update - U.S. 1 Bridge over Jupiter Inlet – final design option to include provisions for both bicyclists and pedestrians

- F. General Public Comments and Public Comments on Agenda Items

Any members from the public wishing to speak at this meeting must complete a Comment Card which is available at the welcome table. General Public comments will be heard prior to the consideration of the first action item. Public comments on specific items on the Agenda will be heard following the presentation of the item to the Committee. Please limit comments to three minutes.

#### **2. ACTION ITEMS**

- A. 2014 Transportation Alternatives Program (TAP) Grant - Applicant Presentations

Applicants will provide presentations to the BGPAC explaining their project and funding requests. BGPAC will finalize evaluation, scoring, and rankings of applications. The presentation schedule is included as part of this agenda.

**4. ADMINISTRATIVE ITEMS**

- A. Member Comments
- B. Next Meeting – **June 12, 2014**
- C. MOTION TO ADJOURN

**NOTICE**

In accordance with Section 286.0105, *Florida Statutes*, if a person decides to appeal any decision made by the board, agency, or commission with respect to any matter considered at such meeting or hearing, he or she will need a record of the proceedings, and that, for such purposes, he or she may need to ensure that a verbatim record of the proceedings is made, which record includes the testimony and evidence upon which the appeal is to be based.

Public participation is solicited without regard to race, color, national origin, age, sex, religion, disability or family status. Persons who require special accommodations under the Americans with Disabilities Act or persons who require translation services for a meeting (free of charge), please call 561-684-4143 or send email to [MBooth@PalmBeachMPO.org](mailto:MBooth@PalmBeachMPO.org) at least five business days in advance. Hearing impaired individuals are requested to telephone the Florida Relay System at #711.

**Transportation Alternatives Program (TAP)  
Grant Applications  
Presentation Schedule to MPO Bicycle, Greenways, and  
Pedestrian Advisory Committee  
8:30 A.M. to 4:00 P.M.**

**May 1, 2014 BGPAC Meeting**

- 8:30 – 9:00 BGPAC General Business
- 9:00 – 9:30 Riviera Beach – Avenue E Bicycle Mobility Enhancements
- 9:40 – 10:10 Palm Beach Gardens – Enhanced Pedestrian Crossings
- 10:20 to 10:25 Break
- 10:30 – 11:00 West Palm Beach - North Shore Neighborhood Improvements
- 11:10 – 11:40 PBC Safe Routes to School - Overhead Pedestrian Warning Flashers
- 11:50 – 12:50 Lunch
- 1:00 – 1:30 Indian Trail Improvement District – Traffic Calming
- 1:40 – 2:10 Royal Palm Beach – Pedestrian Lighting
- 2:20 – 2:50 Delray Beach – NE 2<sup>nd</sup> Avenue Enhancements
- 3:00 – 4:00 Discussion, Scoring and Adjournment



---

## PALM BEACH METROPOLITAN PLANNING ORGANIZATION

---

2300 N. Jog Rd., 4<sup>th</sup>.Floor, West Palm Beach, Florida 33411-2749

Phone 561.684.4170 Fax 561.242-7165 [www.PalmBeachMPO.org](http://www.PalmBeachMPO.org)

MINUTES  
BICYCLE, GREENWAYS, AND PEDESTRIAN  
ADVISORY COMMITTEE (BGPAC)  
Thursday, April 10, 2014 9:07 A.M.  
Vista Center  
4<sup>th</sup> Floor Conference Room 4E-12  
2300 North Jog Road  
West Palm Beach, Florida

### AGENDA

1. REGULAR ITEMS

- A. Roll Call
- B. Comments from the Chair
- C. Motion to Adopt Agenda for April 10, 2014
- D. Motion to Approve Minutes for March 13, 2014
- E. Coordinator's Report
- F. General Public Comments and Public Comments on Agenda Items

2. ACTION ITEMS

- A. Motion to Recommend Approval of BGPAC Bylaws
- B. Review and Motion – U.S. 1 Bridge Over Jupiter Inlet – Proposed Design Options to Include Provisions for Both Bicyclists and Pedestrians

3. INFORMATION ITEMS

- A. 2040 Long Range Plan – Project Funding Categories, Non-Motorized
- B. Minto West Development

4. ADMINISTRATIVE ITEMS

- A. Member Comments
- B. Next Meeting – May 1, 2014
- C. Motion to Adjourn

**ATTENDANCE – 2014**

<b>MEMBER/ALTERNATE</b>	<b>Jan</b>	<b>Feb</b>	<b>Mar</b>	<b>Apr</b>	<b>May</b>	<b>Jun</b>	<b>Jul</b>	<b>Aug</b>	<b>Sept</b>	<b>Oct</b>	<b>Nov</b>	<b>Dec</b>
<b>CORNELIA WANTZ</b> PBC – TRAFFIC ENGINEERING	A	P	P	P								
<b>JEAN MATTHEWS/John Wildner</b> PBC- PARKS & RECREATION	P	P	Alt.	P								
<b>MICHAEL HOWE/David Wiloch</b> PBC – PLANNING	P	P	P	P								
<b>CHAIR ALEX HANSEN/Denise Malone</b> CITY OF WEST PALM BEACH	P	P	P	P								
<b>MICHAEL OWENS/Joyell Shaw</b> PBC - SCHOOL DISTRICT	P	P	P	P								
<b>JOY PUERTA</b> CITY OF BOCA RATON	P	P	P	P								
<b>RANDAL KREJCAREK</b> CITY OF DELRAY BEACH	E	A	P	P								
<b>BRENDA ARNOLD/Jacquelyn Smith</b> TOWN OF JUPITER	P	P	P	P								
<b>VICE-CHAIR SALLY CHANNON</b> PBC ENVIRONMENTAL RESOURCE MGMNT	P	P	P	P								
<b>OLGA PRIETO/John Darnell</b> VILLAGE OF WELLINGTON	Alt	Alt	P	E								
<b>FDOT – EX OFFICIO</b> JENNIFER FIERMAN	P	P	P	A								
<b>CARISSE LEJEUNE</b> CITY OF BOYNTON BEACH	P	Alt	P	P								
<b>BOB SABIN/Don Braverman</b> BOCA RATON BICYCLE CLUB	P	P	P	P								
<b>BRET BARONAK</b> MPO (non-voting member)	P	P	P	P								

## Other Attendees:

Malissa Booth	MPO, Public Information Officer
Rosemary Rayman	Lake Worth Drainage District
Don Hearing	Coutler-Hearing Landscape Architects
Kate Dewitt	Coutler Hearing Landscape Architects
Luis Costa	URS Consulting
Anthony Sfameni	URS Consulting
Vinod Sandanasamy,	MPO, Senior Transportation Planner

*P - Member present   E - Excused absence   A – Member absent   Alt- Alternate*

1. REGULAR ITEMS

A. Roll Call

CHAIR HANSEN called the April 10, 2014 meeting to order at 9:10 a.m. The secretary called the roll stating that a quorum is present.

B. Comments from the Chair

There were no comments from the Chair.

C. Motion to Adopt Agenda for April 10, 2014

CHAIR HANSEN inquired if there were any additions, deletions or changes to the Agenda.

MR. BARONAK said mentioned that the Minto West presentation is solely for information purposes. No recommendation or motion will be required.

A discussion ensued about changing the order of agenda items. MR. BARONAK asked that the Minto West Development presentation (Information Item 3.B) be discussed before the 2040 Long Range Plan – Project Funding Categories, Non-Motorized (Information Item 3.A).

**A motion was made by MS. LEJEUNE to adopt the revised agenda; seconded by MR. SABIN. The motion carried unanimously.**

D. Motion to Approve Minutes for March 13, 2014

CHAIR HANSEN said in reference to the attendance sheet his representation description should be changed to read “City of West Palm Beach”. “Planning” does not need to be included because he is the sole City representative on the BGPAC. “Planning” is used for his MPO TAC representation because WPB Engineering also serves on that Committee. MR. BARONAK said the correction will be reflected on the April attendance sheet.

**A motion was made by MR. SABIN to approve the minutes of the March 13, 2014 meeting with the correction; seconded by MS. ARNOLD. The motion carried unanimously.**

E. COORDINATOR'S REPORT

MR. BARONAK reported the following:

- Tomorrow night he is invited to participate in West Palm Beach's “Screen on the Green” event put on by the WPB Sustainability Department. He will conduct a program on bicycle/pedestrian safety.
- On Saturday, the South County YMCA in Boynton Beach is having a “Kids Wellness Day.” He will be doing a helmet fitting and other bicycle/pedestrian safety activities.
- Regarding the Transportation Alternatives Grant, at this point he doesn't know how many applications will be submitted; he is hoping for nine or ten. The deadline is April 23<sup>rd</sup> at Noon.
- March is Bicycle Month. There was bike to work challenge in West Palm Beach. Approximately 40 people registered including the MPO Executive Director and CHAIR HANSEN. Pictures from the event are on the MPO Facebook site.

CHAIR HANSEN said that City staff and other participants outside of staff will be recognized by City Commission for their efforts related to such milestones as most miles ridden and most days participating, etc.

F. GENERAL PUBLIC COMMENTS AND PUBLIC COMMENTS ON AGENDA ITEMS

There were no comments from the public.

2. ACTION ITEMS

A. Motion to Recommend Approval of the BGPAC Bylaws

MR. BARONAK said the changes discussed at last month's meeting were incorporated into the new revised Bylaws. One of the primary items was make sure that both member and alternate are mentioned in the Bylaws. MR. BARONAK said this is already reflected in the last paragraph of Section 1.01 as follows:

"If an agency designates a representative and alternate, these terms are used interchangeably."

MR. BARONAK said BGPAC bylaws are now consistent with the TAC and CAC bylaws.

MR. SABIN pointed out that the Committee meets on the 2<sup>nd</sup> Thursday of the month and needs to be corrected in Sec. 3.01. The Bylaws erroneously stated the BGPAC meets on the 3<sup>rd</sup> Thursday of the month.

CHAIR HANSEN asked about the definition of "quorum" and a discussion ensued. The Committee may have a membership seat that does not have a designated member. The quorum is a majority of the designated members at the time of the meeting.

CHAIR HANSEN asked if the list of BGPAC members that indicates their renewal dates for membership can be distributed to the members every three months. MR. BARONAK said he would include this information to the members in July.

CHAIR HANSEN referring to Responsibilities and Functions, Sec. 4.02, asked if "items such as, but not limited to" should be added before the list of responsibilities.

**A motion was made by MS. LEJEUNE to approve the BGPAC Bylaws with the above mentioned changes; seconded by MR. SABIN. The motion carried unanimously.**

B. Review and Motion – U.S. 1 Bridge Over Jupiter Inlet – Proposed Design Options to Include Provisions for Both Bicyclists and Pedestrians

MR. OWENS joined the meeting at 9:45 a.m.

MR. BARONAK said this bridge rehabilitation project related to desired design options for bicycles and pedestrians, was discussed in the past. This project is included in the TIP and is scheduled for letting in 2016. The original design proposal for this project on our TIP makes accommodations for specific pedestrian improvements (i.e. sidewalks) but not specific bicycle accommodations. Staff had discussions about design options for incorporating measures into the bridge design that will allow for specific bicycle accommodations.

MR. BARONAK said today's presentation will explain the original design and incremental improvements to incorporate a design that better accommodates bicyclists. He wants the BGPAC to think about what is being proposed. MR. COSTA with URS Corporation, the FDOT consultant, will explain some of the design options and safety issues.

The Committee followed along with MR. COSTA's presentation answering in detail any questions the members' raised.

MS. LEJEUNE asked if it is possible to make a motion that this committee approves this design with the caveat that if they can find a way to shrink the median and expand the outer shoulders, then we recommend undertaking those measures.

MS. PUERTA said she doesn't agree with that version presented, but she doesn't want to hold up the funding. She suggests the following motion:

**A motion was made by MS. PUERTA to support additional funds to include provisions for bicyclists and pedestrian facilities along the U.S 1 Bridge over Jupiter Inlet; however, explore designing the median at a narrower width to accommodate additional room (width) on both sides for bicyclists and/or provide a minimum ten foot (10') wide sidewalk on both sides of the bridge; seconded by MS. ARNOLD.**

The discussion continued and MR. BARONAK stated a decision has to be made on this quickly or this whole production schedule will be thrown off and this will create a scenario where money can be lost.

MR. COSTA said the motion is fine. There is going to be a bridge project moving forward and final bike/ped measures will be determined. MS. PUERTA's motion lets FDOT go the next step. He will review the median again but he is relatively sure that the change has been considered and is unlikely, but not ruled out completely.

CHAIR HANSEN said that while the median reduction may not get us a full width for a bicycle lane; even a small increase in width would be a significant gain and help to minimize conflicts between bikes and cars.

CHAIR HANSEN said there is a motion and a second still on the table and asked if there is any more discussion on the motion. There was no further discussion. **The motion carried unanimously.**

### 3. INFORMATION ITEMS

#### B. Minto West Development

MR. DON HEARING with Coulter-Hearing, the land planning agent for the Minto West Development, presented information regarding the Minto West Community development in west central County. He provided the Committee with the development plans for the Minto West Community, which is 3750 acres surrounded by 33 square miles (Acreage Community) of largely one acre gridded lots with no public water and sewer and primarily unpaved roadways. The most significant road that runs through the project is Seminole Pratt-Whitney which divides the Minto West project. He further described the mixed-use elements of development planned for what is known as Callery-Judge Grove property – the property on which this development is located. The Committee members followed his presentation with a focus on the bicycle and pedestrian component of the development's transportation network. This was strictly an information item and no motion was taken.



## A. 2040 Long Range Plan – Project Funding Categories, Non-Motorized

MR. BARONAK explained to the Committee a new direction the MPO wants to take as it relates to our Long Range Transportation Plan (LRTP). He explained in the past the LRTP has been a “road program.” As far as it related to non-motorized transportation, a lot of what we did in past LRTP’s is look at our enhancement program as the specific bike/ped portion. It was understood that bike/ped projects will come out of the transportation enhancement program or they will be included in roadway projects that are identified in the LRTP. Now as we work on our 2040 plan we are categorizing projects in the LRTP. We are looking at four major categories of funding consisting of the MPO Federal Surface Urban Transportation Funds (SU). The categories are transportation system management (i.e. signal improvements along a corridor), transit, freight and finally a category for non-motorized projects (i.e. bike/ped projects). Typically most of those projects are going to be smaller dollar amounts (under \$5 million) so they will not be listed as a major project somewhere else in the LRTP. Because they are less than \$5 million, perhaps several hundred thousand or \$1-2 million, they do not need to be listed explicitly in the LRTP. Essentially we can take from a list of projects such as the bicycle master plan priorities, or take input on projects from local municipalities that represent desired local bike/ped projects, and go through a competitive process to fund non-motorized through this categorical funding. The detail on the categorical approach is still a work in progress.

In the past this Committee has already approved the tier one bike projects that came out of the Master Plan. As mentioned prior, that would be one of the projects listings from which to be drawn. Last year, when it came time to provide input on new projects for MPO funding priorities, a couple of non-motorized projects added were the expansion of the pathway along Palmetto Park Road in Boca Raton and the construction of a new sidewalk at Gove Elementary School on Avenue G in Belle Glade.

The benefit of this new approach is specifically identifying stand-alone non-motorized projects in a funding category exclusive for these types of projects. This empowers the BGPAC to be involved in project selection. Not only will the BGPAC be evaluating the Transportation Alternatives applications, but will also rank and score non-motorized projects through the project prioritization process for inclusion on the TIP. This Committee would make the decision on which of those projects would get funded.

MR. BARONAK said at this time he is not aware of what the exact amount of funding will be from year to year. But he anticipates it averaging approximately \$16 million a year for the SU funds. This means 25% of that (approximately \$4 million) will be the allocation to work from annually. This is about twice as much as we typically get with the transportation alternatives program.

MR. BARONAK said the TAC and CAC have heard the presentation on the categorical funding approach and he understands they are in agreement with the approach. MR. BARONAK said he believes this approach will be very beneficial to providing more emphasis on non-motorized projects.

MR. HANSEN mentioned that the other categories within this approach such as transportation system management may also be of interest to the BGPAC as elements in those projects may relate directly to a non-motorized improvement.

MR. BARONAK said he thinks there may be some room within the transit category too that could have specific bike/ped components (i.e. additional bike racks). He believes the Committee would have the opportunity to provide input on those projects in any of the other categories that have relevant non-motorized aspects.

MR. BARONAK reiterated that the MPO doing a focused evaluation on specific bike/ped projects will empower the BGPAC even more. MR. BARONAK said even beyond the funding categories, he thinks the way the approach to be taken at the MPO will generate much more involvement from all of the MPO's Committees on all types of transportation projects.

MR. BARONAK explained the timing aspect of this approach to evaluate project priorities and it may overlap with the annual TAP process. Thus, there may be an effort made to undertake both the TAP and Priorities at the same time so there are not two separate events required by the BGPAC and be challenging to members' schedules.

MS. MATTHEWS asked that more information on this approach be presented at a future meeting. MR. BARONAK said we may have more details in place by the June BGPAC meeting,

#### 4. ADMINISTRATIVE ITEMS

##### A. Member Comments

MS. MATTHEWS asked if we can once again have the GIS data to zoom in on a project for further clarification in understanding the spatial context of the project. Last year there was a rule that the Committee could not look at any of the GIS maps until after the applicant left the room. It might actually be helpful if we have the GIS maps up while the applicant is in the room in case we have questions.

MR. BARONAK said we will access the GIS maps/Google Earth if needed.

MR. BARONAK said at May 1<sup>st</sup> meeting, general business will start at 8:30 A.M. then at 9:00 A.M. we will start the applicant presentation process.

##### B. NEXT MEETING – May 1, 2014

##### C. MOTION TO ADJOURN

**There being no further business, a motion was made by MR. SABIN to adjourn the meeting at 11:30 a.m.; seconded by MS. LEJEUNE. The motion carried unanimously.**

---

This signature is to attest that the undersigned is the Chairperson, or a designated nominee, of the Bicycle, Greenways, and Pedestrian Advisory Committee and that information provided herein is the true and correct Minutes for the **April** meeting of the Bicycle, Greenways, and Pedestrian Advisory Committee, dated this \_\_\_\_\_ day of \_\_\_\_\_, 2014.

\_\_\_\_\_  
Chairperson

**RECORDED TAPES OF ALL BICYCLE, GREENWAYS, AND PEDESTRIAN ADVISORY COMMITTEE MEETINGS ARE KEPT ON FILE AT THE METROPOLITAN PLANNING ORGANIZATION OFFICE.**

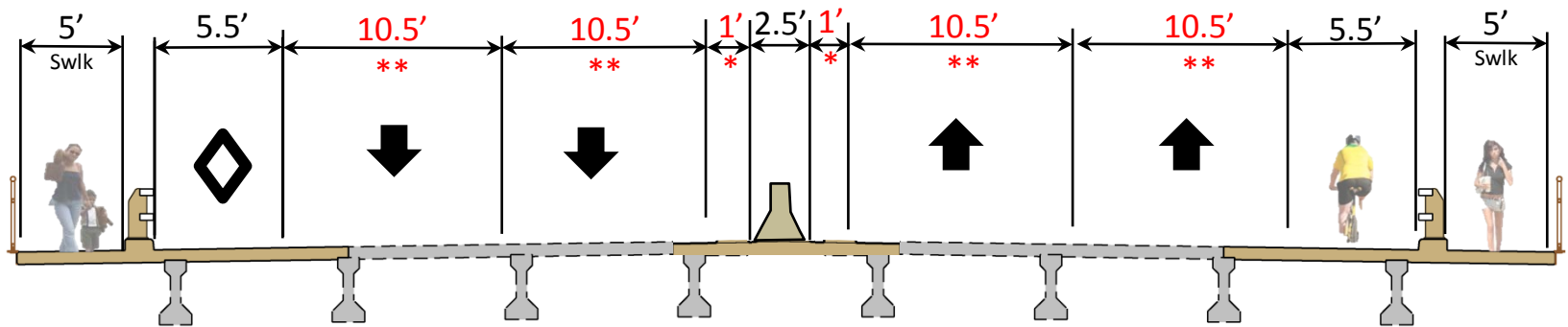

*\* Median Shoulder Width Design Variation Required (PPM Figure 2.0.4) (6' Min. for Long Bridge)*

*\*\* Lane Width Variation Required*

- *Requires Minor Foundation Work*

## Optional Fixed Bridge Typical Section

# SR-5 /US-1 Jupiter Federal Highway Bridge

FM No. 428400-1-52-01

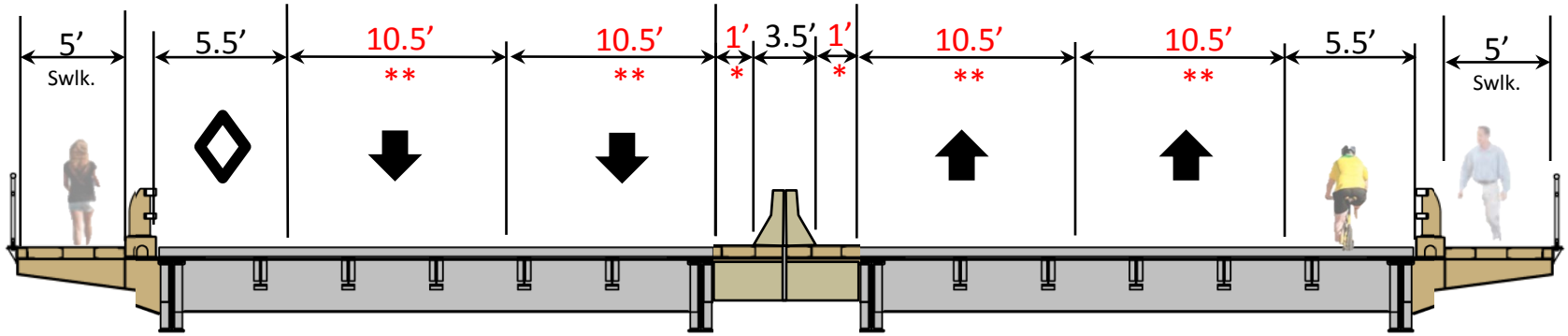

\* Median Shoulder Width Design Variation Required (PPM Figure 2.0.4) (6' Min. for Long Bridge)

\*\* Lane Width Variation Required

## Optional Bascule Bridge Typical Section